



IAI
Impedance Analysis Interface

USER MANUAL



“ Do not be hasty when making measurements.”

The **Impedance Analysis Interface** is a precision accessory designed for use with PSM17xx range instruments. These instruments provide you with the tools to make a wide variety of measurements accurately, reliably, and efficiently - but good metrology practice must be observed. Take time to read this manual and familiarise yourself with the features of the instrument in order to use it most effectively.

IMPORTANT SAFETY INSTRUCTIONS

This equipment is designed to comply with BSEN 61010-1 (Safety requirements for electrical equipment for measurement, control, and laboratory use) – observe the following precautions:

- Ensure that the supply voltage agrees with the rating of the instrument printed on the back panel **before** connecting the mains cord to the supply.
- This appliance **must** be earthed. Ensure that the instrument is powered from a properly grounded supply.
- High voltages can be generated if current flow to inductive components is interrupted. Turn off the output before connecting or disconnecting any component.
- Keep the ventilation holes on the underneath and sides free from obstruction.
- Do not operate or store under conditions where condensation may occur or where conducting debris may enter the case.
- There are no user serviceable parts inside the instrument – do not attempt to open the instrument, refer service to the manufacturer or his appointed agent.

Note: Newtons4th Ltd. shall not be liable for any consequential damages, losses, costs or expenses arising from the use or misuse of this product however caused.

DECLARATION OF CONFORMITY

Manufacturer: Newtons4th Ltd.
Address: 1 Bede Island Road
Leicester
LE2 7EA

We declare that the product:

Description: Impedance analysis interface
Product name: IAI
Model:

conforms to the requirements of Council Directives:

89/336/EEC relating to electromagnetic compatibility:
EN 61326:1997 Class A

73/23/EEC relating to safety of laboratory equipment:
EN 61010-1

April 2005

Eur Ing Allan Winsor BSc CEng MIEE
(Director Newtons4th Ltd.)

WARRANTY

This product is guaranteed to be free from defects in materials and workmanship for a period of 36 months from the date of purchase.

In the unlikely event of any problem within this guarantee period, first contact Newtons4th Ltd. or your local representative, to give a description of the problem. Please have as much relevant information to hand as possible.

If the problem cannot be resolved directly then you will be given an RMA number and asked to return the unit. The unit will be repaired or replaced at the sole discretion of Newtons4th Ltd.

This guarantee is limited to the cost of the IAI itself and does not extend to any consequential damage or losses whatsoever including, but not limited to, any loss of earnings arising from a failure of the product or software.

In the event of any problem with the instrument outside of the guarantee period, Newtons4th Ltd. offers a full repair and re-calibration service – contact your local representative.

It is recommended that the IAI be re-calibrated annually along with the measurement instrument that it is used with.

ABOUT THIS MANUAL

The Impedance Analysis Interface from Newtons4th Ltd (IAI) is a precision interface for use with the phase sensitive multimeter range of test instruments, PSM1700 PsimetriQ and PSM1735 NumetriQ, for impedance analysis applications.

This manual is concerned specifically with the IAI and its use to measure impedance – a working knowledge is assumed of the PSM instrument that it is used with.

Detailed descriptions of the PSM1700 PsimetriQ and PSM1735 NumetriQ may be found in the appropriate user manual.

Revision 1.00

This manual is copyright © 2005 Newtons4th Ltd. and all rights are reserved. No part may be copied or reproduced in any form without prior written consent.

1 Jun 2005

CONTENTS

1	Impedance analysis – an overview	1-1
2	Getting started	2-1
2.1	Unpacking	2-1
3	Using the IAI	3-1
3.1	Shunt selection	3-3
3.2	Selecting test conditions	3-6
4	Connecting to the DUT	4-1
4.1	Kelvin leads	4-1
4.2	High frequency fixture	4-2
4.3	Direct connection to BNC	4-3
4.4	Custom fixtures	4-4
5	Compensation	5-1
5.1	Short circuit compensation	5-2
5.2	Open circuit compensation	5-3
5.3	Reference load compensation	5-4
6	Calibration	6-1
7	Specification	7-1

Impedance analysis interface user manual

APPENDICES

Appendix A Accessories

Appendix B Contact details

1 Impedance analysis – an overview

Real components are never ideal resistors, capacitors or inductors because of unwanted parasitic effects arising from their construction.

It is useful to model a real component as an appropriate combination of ideal resistance, capacitance and inductance. For example, a real inductor at a frequency below its resonant frequency may be modelled as a pure inductor with a series resistance; a real resistor may be modelled either as a pure resistor with a series inductance or by a pure resistor with a parallel capacitance; a capacitor is most commonly modelled as a pure capacitor with a series resistance (ESR).

The parameters of real components vary with the conditions of frequency and voltage/current under which they are used.

In many cases, components are used under conditions where the parasitic effects of the component become critical and must be measured reliably over a wide range of operating conditions.

The impedance is analysed by measurement of the complex impedance, **Z**, under controlled conditions of frequency and voltage or current:

$$\mathbf{Z} = \mathbf{V} / \mathbf{I}$$

where **V** is the voltage across the component
I is the current through the component

Z, **V** and **I** are complex values which may be represented as magnitude and phase or by in-phase and quadrature components. The LCR measurement is performed by the PSM instrument using a discrete Fourier transform (DFT)

Impedance analysis interface user manual

at the frequency of operation. This gives the complex impedance directly in the form of an in-phase component and a quadrature component.

Having measured the complex impedance, **Z_m**, in the form of in-phase, **Z_r**, and quadrature components, **Z_q**, the series and parallel models can then be computed.

Using traditional complex mathematical notation where **j** is the operator $\sqrt{-1}$:

$$\mathbf{Z_m} = Z_r + j Z_q$$

For the series inductance model ($Z_q > 0$):

$$\mathbf{Z} = R_s + j \omega L_s$$

where $\omega = 2 \cdot \pi \cdot \text{frequency}$

and:

$$R_s = Z_r$$

$$L_s = Z_q / \omega$$

For the parallel capacitance model ($Z_q < 0$):

$$1/\mathbf{Z} = 1/R_p + j \omega C_p$$

and:

$$R_p = (Z_r^2 + Z_q^2) / Z_r$$

$$C_p = - Z_q / \omega \cdot (Z_r^2 + Z_q^2)$$

It is important to characterise the component over all the frequencies that are relevant for a given applications. For this reason, the **IAI** can be used with the phase sensitive

Impedance analysis interface user manual

multimeters from Newtons4th Ltd to sweep across a frequency range.

2 Getting started

The IAI is supplied with appropriate leads and accessories for use with either the PSM1700 PsimetriQ or PSM1735 NumetriQ phase sensitive multimeters from Newtons4th Ltd. The IAI should be calibrated with the unit that it will be used with – see the later chapter on calibration.

2.1 Unpacking

Inside the carton there should be the following items:

- one IAI unit
- one appropriate mains lead
- three short BNC cables
- one short ribbon cable
- a pair of Kelvin leads for low frequency use
- this manual

There may also be a number of optional accessories if these have been ordered with the unit.

Having verified that the entire above list of contents is present, it would be wise to verify that your IAI operates correctly and has not been damaged in transit.

Site the IAI under the instrument that it will be used with. Connect the 3 short BNC cables from the BNC connectors on the front of the IAI (OUT, CH1, and CH2) to the corresponding BNC connectors on the PSM above it. Connect the ribbon cable from the extension port on the back of the IAI to that of the PSM.

Connect the red Kelvin lead to the signal+ and sense+ BNC connectors on the front of the IAI, and connect the black Kelvin lead to the sense- and signal- BNC

Impedance analysis interface user manual

connectors. Connect the Kelvin clips across an appropriate test component, eg. a 100nF capacitor.

Verify that the voltage ratings on the rear panels of the IAI and the instrument are appropriate for the supply, then connect the mains cords to the inlets on the rear panels and the supply outlet.

Switch on the IAI and the instrument. All four leds on the front of the IAI should illuminate. The display on the instrument should illuminate with the model name and the firmware version for a few seconds while it performs some initial tests. It then normally defaults to the RMS voltmeter display unless some other mode has been stored into the start-up program (PROG 1).

Press the AUX key on the instrument and select fixture = "IAI" and LCR head shunt = "normal". Only the normal LED should now be illuminated on the front panel of the IAI.

If the instrument displays the message:

"FIXTURE NOT RESPONDING"

then check that the extension port cable has not been damaged and has been correctly fitted between the instrument and the IAI.

If the message does not appear but all 4 leds remain illuminated then check that the IAI is correctly connected to the supply and that the fuse is intact.

Press the OUT key on the instrument and turn on the output.

Impedance analysis interface user manual

Press the LCR key to select the impedance analyser function and check that the test component is measured correctly.

In the event of any problem with this procedure, please contact customer services at Newtons4th Ltd. or your local authorised representative: contact addresses and telephone numbers are given in the appendix at the back of this manual.

3 Using the IAI

The device under test (DUT) is measured by the IAI in a configuration where the component is ground referenced. This allows the IAI to be used to measure the impedance of devices even when one terminal is connected to earth.

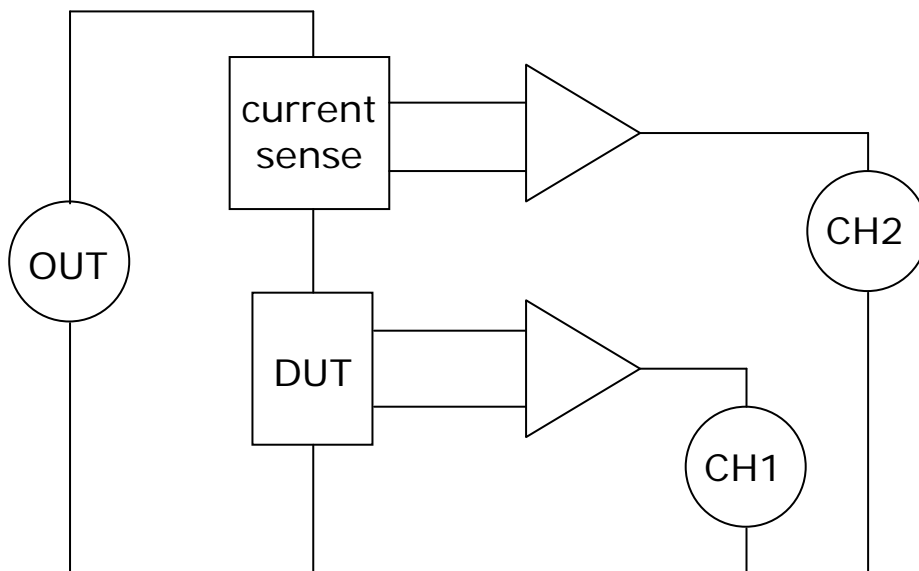

The IAI has 4 selectable 'shunts' to sense the current through the device under test:

'shunt'	value	comments
LOW	5Ω	also has 1A pk buffer
NORMAL	50Ω	
HIGH	5kΩ	
VERY HIGH	500kΩ	not recommended above 1kHz

Impedance analysis interface user manual

When the 'shunt' is selected on the instrument via the AUX menu, the resistance value is automatically entered as the external shunt for channel 2. The 'shunt' may be selected manually or the PSM can be configured to select it automatically.

Not shown on the diagram for clarity is the 50Ω terminator on the 'OUT' input connecting to the output of the PSM instrument and the 50Ω balancing resistors on 'CH1' and 'CH2' outputs connecting to the inputs of the PSM.

For high precision measurement under some conditions it may be necessary to compensate for parasitics within the test connections – see the later chapter on compensation.

3.1 Shunt selection

The different 'shunts' built into the IAI allow the test conditions to be modified to optimise the measurement accuracy. In general a higher value shunt increases the magnitude of the current signal and decreases the magnitude of the voltage signal; conversely a lower value shunt decreases the magnitude of the current signal and increases the magnitude of the voltage signal.

Optimum accuracy is when the voltage and current signals are approximately equal (the impedance of the shunt is approximately the same as the impedance of the DUT), but good results can be obtained with impedances within a factor of 100 of the shunt value.

The accuracy also depends on the frequency of operation. For example, considering the normal shunt, used with the PSM1735 NumetriQ, with the high frequency fixture fitted directly to the front of the IAI, the accuracy is tabulated below:

'normal' shunt accuracy table

accuracy	impedance range	frequency range
0.1%	5Ω to 500Ω	10Hz to 100kHz
1%	5Ω to 500Ω 500mΩ to 5kΩ	1Hz to 1MHz 10Hz to 100kHz
10%	5Ω to 500Ω 500mΩ to 5kΩ 50mΩ to 50kΩ	100uHz to 25MHz 1Hz to 1MHz 10Hz to 100kHz
20%	5Ω to 500Ω 500mΩ to 5kΩ 50mΩ to 50kΩ	10uHz to 35MHz 100uHz to 5MHz 10Hz to 100kHz

Impedance analysis interface user manual

It is necessary to take great care in order to achieve the best accuracy of measurement. The leads of the component must be scrupulously clean and for repeatability, the component must be connected in exactly the same position. Slight variations in connection can result in significantly different measured values, especially at high frequencies.

In general, the “very high” shunt should only be used for high impedance measurements ($>1\text{M}\Omega$) at low frequencies ($<1\text{kHz}$).

The “low” shunt is used with higher current testing of low impedances as it includes a current boosting amplifier that can deliver up to 0.5A rms.

Warning: high voltages can be generated when the current flowing through an inductive component is interrupted. So turn the output off before disconnecting an inductive or unknown component.

The “normal” and “high” shunts are general purpose and between them cover a very wide impedance range.

shunt frequency ranges

shunt	impedance range	frequency range
low	$<50\Omega$	$<10\text{MHz}$
normal	$50\text{m}\Omega$ to $50\text{k}\Omega$	all
high	5Ω to $5\text{M}\Omega$	all
very high	$>1\text{M}\Omega$	$<1\text{kHz}$

Of course, this table is only a guide and each ‘shunt’ can be used beyond the limits quoted.

Impedance analysis interface user manual

If automatic shunt selection is configured on the instrument then the appropriate shunt will be automatically selected according to the test conditions and the measured impedance.

3.2 Selecting test conditions

The frequency and voltage of the generator are selected on the PSM instrument. The actual voltage across the DUT depends on the impedance of the component at the test frequency and the impedance of the selected shunt.

If the generator output is set as a peak voltage V_{pk} , then because of the 50Ω impedances the rms voltage across the series combination of shunt and DUT may be approximated as $V_{pk}/2\sqrt{2}$ with a series resistance of 25Ω .

Then the voltage seen by the DUT, V_{dut} , will be approximately given by:

$$V_{dut} \approx V_{pk}/2\sqrt{2} \times Z_{dut}/(Z_{dut} + R_{shunt} + 25)$$

where: Z_{dut} = impedance of the DUT
 R_{shunt} = resistance of the 'shunt'

The PSM instrument clearly displays the measured voltage across the DUT and the measured current through it.

To fix the test voltage at a specified level, enable ac trim on CH1 using the TRIM menu on the instrument and set the desired rms level for V_{dut} . The instrument will then adjust the generator output level until the measured voltage across the component is as specified.

Note that the low shunt also has a high speed buffer so the 25Ω term does not appear, and the equation becomes:

$$V_{dut} \approx V_{pk}/2\sqrt{2} \times Z_{dut}/(Z_{dut} + 5)$$

The maximum rms current, I_{max} , in this case into a short circuit becomes:

$$I_{max} \approx 10/2\sqrt{2} / 5$$

Impedance analysis interface user manual

$\sim = 0.7A$ rms

The optimum test conditions to use depend on the component or DUT and the application as many components change their characteristics with frequency and test voltage. The PSM instrument can automatically select test conditions or they can be entered manually.

DC offsets can also be added to the test voltage where needed, for example testing electrolytic capacitors which need a bias voltage. In this case, it may be best to set the PSM instrument to AC coupling which will increase the measured accuracy in cases where the AC signal is small relative to the DC level.

4 Connecting to the DUT

4.1 Kelvin leads

The IAI is supplied with a pair of Kelvin leads for low frequency use (<5MHz) which make simple connections to a discrete component.

The red lead should be connected to the BNC connectors marked SIGNAL+ and SENSE+ on the front of the IAI; the black lead should be connected to the BNC connectors marked SIGNAL- and SENSE-.

The Kelvin clips can then be clipped onto the body of the component, as close as possible to the component.

For accurate measurements it is essential that the component leads are clean. For repeatability of measurements, it is important to connect the Kelvin clips in the same physical arrangement when testing different components.

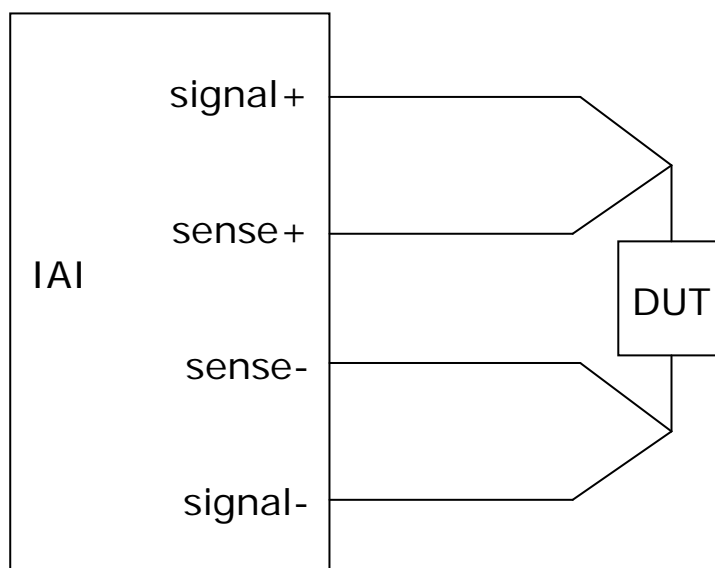

4.2 High frequency fixture

For testing components over all frequencies, there is a dedicated test fixture available as an accessory from Newtons4th Ltd. This can clip directly onto the front of the IAI by means of four BNC to BNC couplers supplied with it to minimise effects due to cabling.

Connection is made to the component by four gold plated contact areas in a four-wire Kelvin arrangement; SIGNAL+ and SIGNAL- appear on the lower pair of contacts, SENSE+ and SENSE- are picked up from the upper pair of contacts.

The lower pair of contacts are secured to the connectors attached to the IAI and does not move; the upper pair of contacts can be lifted by light finger pressure. The contacts are pressed closed by springs.

To insert a component push up the upper contact plate so that the legs of the component can be inserted. If necessary push up the upper contact plate on one side first and then the other side so that the component can be pushed home. For high frequency work it is essential for the component to be inserted as far as possible.

The HF fixture does not have to be clipped to the front of the IAI but can be used with some short BNC leads instead of the BNC couplers.

4.3 Direct connection to BNC

Because the DUT is ground referenced by the IAI (SIGNAL- is connected to earth), the IAI can be used to directly measure the input and output impedances of equipment which is earthed eg. oscilloscope inputs.

The easiest way to make the connections is to use the BNC connection kit available as an accessory, consisting of:

- Dual BNC adaptor
- BNC lead
- BNC splitter lead

Ensure that there are no harmful voltages present on the BNC connector to be tested.

Connect the 'dual BNC adaptor' to the BNC terminal which is to be measured. Connect the 'BNC lead' from one end of the adaptor to the SIGNAL+ terminal of the IAI. Connect the single BNC end of the 'BNC splitter lead' to the other end of the adaptor; connect the BNC with the red boot to the SENSE+ terminal of the IAI; connect the BNC with the black boot to the SENSE- terminal. The SIGNAL- terminal is not used in this configuration.

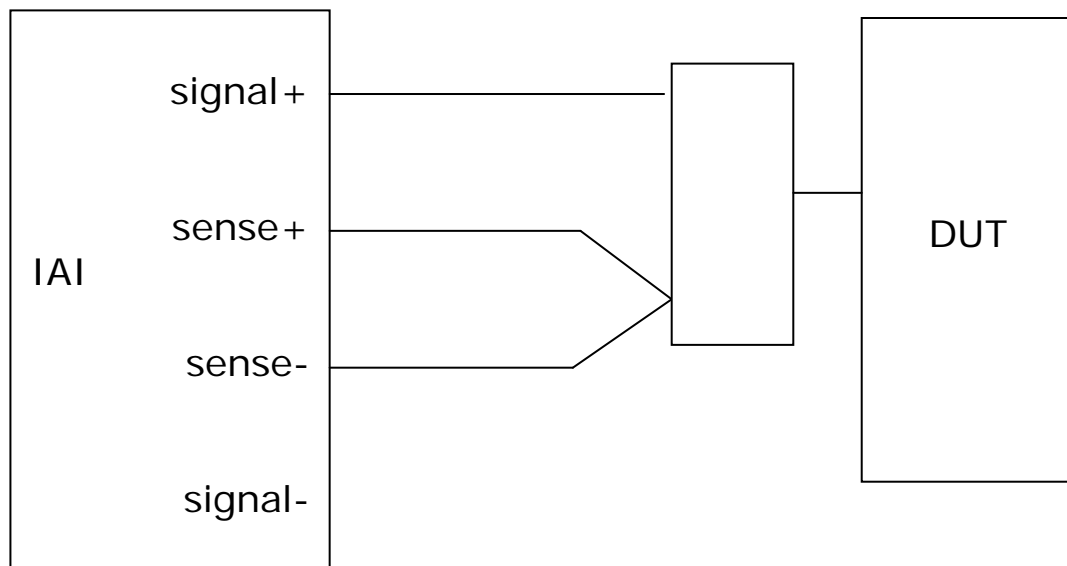

4.4 Custom fixtures

For dedicated test facilities, the IAI can be used with custom made fixtures.

The test voltage is provided at the SIGNAL+ terminal, and the selected internal current sense circuitry measures the current that is drawn from this terminal. The voltage across the DUT should be presented to the high impedance SENSE+ and SENSE- terminals. The SIGNAL- terminal is not used in this configuration.

For remote operation at a distance from the IAI, the fixture could have active buffers to drive the SENSE+ and SENSE- cables to isolate the effects of the cabling from the DUT. Use high impedance amplifiers (eg JFET input types), in x2 mode with the characteristic resistance for the cable being used (usually 50Ω), and terminate the cables at the IAI with the same value.

The AUX connector on the IAI provides +/-12V at up to 50mA per rail for powering active fixtures. The outputs are current limited with self resetting fuses. Local smoothing capacitors and possibly voltage regulators are advisable on the custom fixture.

The AUX connector is a 3.5mm stereo jack socket with the following pinout:

barrel	0V
middle	-12V
tip	+12V

5 Compensation

Any cables or fixtures used to interface the device under test to the IAI will introduce measurement errors because of the stray impedances. At low frequencies the stray effects can usually be ignored except when measuring at the extremes of the impedance range or when exceptionally high accuracy is needed. At higher frequencies it is almost always necessary to compensate for the stray effects unless using the HF component fixture clipped to the front of the IAI.

There are 3 forms of compensation:

1. Short circuit – for measuring low impedance
2. Open circuit – for measuring high impedances
3. Reference load compensation – for highest accuracy.

It is usually only necessary to perform one of the three forms of compensation but any two or all three can be performed. For best results, if more than one is to be performed they should be performed in the sequence given above.

In the following descriptions, the impedances are shown in bold type, eg **Z_x**, to indicate that they are complex values with in-phase and quadrature components.

5.1 Short circuit compensation

Short circuit compensation compensates for the stray impedance in series with the impedance to be measured:

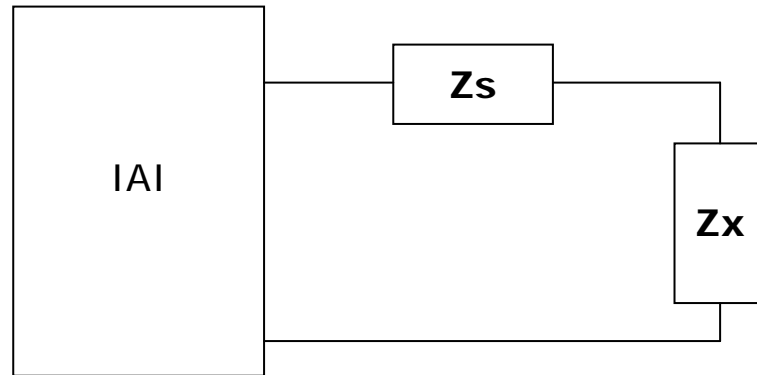

Then, if **Z_m** is the impedance measured by the IAI:

$$\mathbf{Z_m} = \mathbf{Z_s} + \mathbf{Z_x}$$

To compensate for **Z_s**, a measurement is made with the DUT shorted out but with all the cables in the same place. This measures **Z_s** directly and is stored as **Z_s**.

Then the DUT is replaced without disturbing any wiring and the true **Z_x** can be derived from **Z_m** and **Z_s**:

$$\mathbf{Z_x} = \mathbf{Z_m} - \mathbf{Z_s}$$

5.2 Open circuit compensation

Open circuit compensation compensates for the stray impedance in parallel with the impedance to be measured:

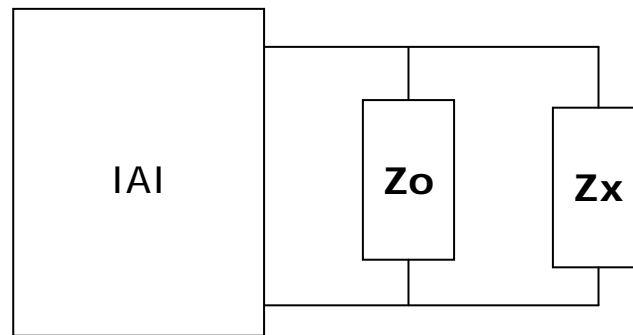

Then, if **Z_m** is the impedance measured by the IAI:

$$1/\mathbf{Z}_m = 1/\mathbf{Z}_o + 1/\mathbf{Z}_x$$

To compensate for **Z_o**, a measurement is made with the DUT removed but with all the cables in the same place. This measures **Z_o** directly and is stored as:

$$\mathbf{Y}_o = 1/\mathbf{Z}_o$$

Then the DUT is replaced without disturbing any wiring and the true **Z_x** can be derived from **Z_m** and **Y_o**:

$$1/\mathbf{Z}_x = 1/\mathbf{Z}_m - \mathbf{Y}_o$$

or:

$$\mathbf{Z}_x = \mathbf{Z}_m / (1 - \mathbf{Y}_o \cdot \mathbf{Z}_m)$$

5.3 Reference load compensation

Reference load compensation compensates for complex effects within the cabling and fixtures by measuring a known reference component. The value of the reference component and its phase are entered and the measured value stored.

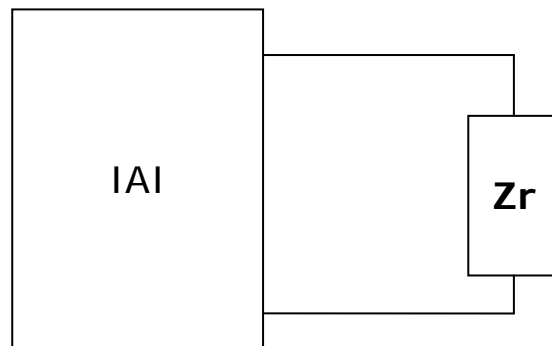

Then, if **ZI** is the impedance measured by the IAI with the known reference impedance **Zr** connected and **Zm** is the impedance measured by the IAI with the DUT connected:

$$\mathbf{Zx} = \mathbf{Zm} \cdot \mathbf{Zr} / \mathbf{ZI}$$

6 Calibration

For optimum accuracy, the IAI should be re-calibrated annually with the instrument that it is used with. The calibration values are stored in the instrument so the IAI and PSM instrument should be kept together as a pair.

The calibration process is similar to compensation except that it is performed over a series of frequencies. The reference components used for the calibration are resistors of the same value as the internal current sense shunts.

The calibration procedure is controlled by a script file, running under CommVIEW, which instructs the operator to fit the appropriate fixture then sends the necessary commands to the instrument.

The calibration fixture set comprises:

- 4 BNC to BNC couplers
- 1 or more short circuit fixtures
- 1 or more open circuit fixtures
- 4 reference fixtures
- 1 script file to run under CommVIEW.

The calibration process stores the measured value for **Zs**, **Yo**, and **ZI** for each frequency point, and **Zr**.

Then, if **Zm** is the impedance measured by the IAI:

$$\mathbf{Zx} = \mathbf{Zr} \cdot \frac{(1 - (\mathbf{ZI} - \mathbf{Zs}) \cdot \mathbf{Yo})}{(1 - (\mathbf{Zm} - \mathbf{Zs}) \cdot \mathbf{Yo})} \frac{(\mathbf{Zm} - \mathbf{Zs})}{(\mathbf{ZI} - \mathbf{Zs})}$$

Interpolation is used to determine the constants for frequencies between calibration points

Impedance analysis interface user manual

7 Specification

All these specifications are quoted for the system consisting of IAI with HF fixture and PSM17xx NumetriQ unless otherwise stated.

System		
	PSM1700	PSM1735
Frequency range	10uHz – 1MHz	10uHz – 35MHz
Basic accuracy	0.25%	0.1%
Impedance range	10mΩ – 100MΩ 10pF – 1000uF 100nH – 10kH	
Excitation voltage	5Vpk max	
Excitation control	voltage or current	
Configuration	ground referenced	
DC offset voltage	+/- 5V max	
Parameters measured	R, L, C, Z, phase, QF, tan(δ) series or parallel circuit	
selectable shunts	4	
buffer current (low shunt)	0.5A rms max	

IAI only	
connectors	grounded BNC
power requirements	universal input 90-264V rms, 47-63Hz 15VA max.
size	60H x 350W x 250D mm approx
weight	2kg approx
temperature range	5 to 35°C

Impedance analysis interface user manual

For each shunt, the accuracy of measurement depends on the impedance and the frequency.

'normal' shunt accuracy table

accuracy	impedance range	frequency range
0.1%	5Ω to 500Ω	10Hz to 100kHz
1%	5Ω to 500Ω 500mΩ to 5kΩ	1Hz to 1MHz 10Hz to 100kHz
10%	5Ω to 500Ω 500mΩ to 5kΩ 50mΩ to 50kΩ	100uHz to 25MHz 1Hz to 1MHz 10Hz to 100kHz
20%	5Ω to 500Ω 500mΩ to 5kΩ 50mΩ to 50kΩ	10uHz to 35MHz 100uHz to 5MHz 1Hz to 500kHz
Phase Accuracy	0.05°+ 0.005° / kHz	

'high' shunt accuracy table

accuracy	impedance range	frequency range
0.1%	500Ω to 50kΩ	10Hz to 100kHz
1%	500Ω to 50kΩ 50Ω to 500kΩ	1Hz to 1MHz 10Hz to 100kHz
10%	500Ω to 50kΩ 50Ω to 500kΩ 5Ω to 5MΩ	100uHz to 15MHz 1Hz to 1MHz 10Hz to 100kHz
20%	500Ω to 50kΩ 50Ω to 500kΩ 5Ω to 5MΩ	10uHz to 35MHz 100uHz to 5MHz 1Hz to 500kHz
Phase Accuracy	0.05°+ 0.005° / kHz	

Impedance analysis interface user manual

'low' shunt accuracy table

accuracy	impedance range	frequency range
0.1%	500mΩ to 50Ω	10Hz to 100kHz
1%	500mΩ to 50Ω 50mΩ to 500Ω	1Hz to 1MHz 10Hz to 100kHz
10%	500mΩ to 50Ω 50mΩ to 500Ω 10mΩ to 5kΩ	100uHz to 10MHz 1Hz to 1MHz 10Hz to 100kHz
Phase Accuracy	$0.1^{\circ} + 0.01^{\circ} / \text{kHz}$	

'very high' shunt accuracy table

accuracy	impedance range	frequency range
0.1%	50kΩ to 5MΩ	10Hz to 1kHz
1%	50kΩ to 5MΩ 5kΩ to 50MΩ	1Hz to 1kHz 10Hz to 1kHz
10%	50kΩ to 5MΩ 5kΩ to 50MΩ 500Ω to 100MΩ	100uHz to 1kHz 1Hz to 1kHz 10Hz to 1kHz
Phase Accuracy	$0.1^{\circ} + 0.05^{\circ} / \text{kHz}$	

Appendix A – Accessories

ACCESSORIES

Impedance analysis interface user manual

High frequency component fixture

The high frequency component fixture clips onto the front of the IAI with four BNC coupling adaptors (supplied) for easy testing of components.

Part numbers

500-066 HF impedance fixture

Impedance analysis interface user manual

BNC connection adaptor

The IAI can be used to directly measure the impedance of inputs and outputs of other equipment even if the BNC connector is grounded.

The BNC connection kit consists of :

- Dual BNC adaptor
- BNC lead
- BNC splitter lead

Part numbers

500-067 BNC connection adaptor

Calibration kit

The IAI is calibrated with the instrument that it is used with, by means of a series of calibration fixtures. Open circuit, short and circuit and reference load calibration is performed for each shunt and the values stored in the non-volatile FLASH memory of the instrument.

The calibration kit includes all the necessary fixtures, four BNC coupling adaptors to fit them to the front of the IAI and a disc with the script file to run under CommVIEW.

Part numbers

500-072 IAI calibration kit

Appendix B – Contact details

Please direct all queries or comments regarding the PsimetriQ instrument or manual to:

Newtonson4th Ltd.
1 Bede Island Road
Leicester
LE2 7EA
United Kingdom

Tel: (0116) 230 1066 international +44 116 230 1066
Fax: (0116) 230 1061 international +44 116 230 1061

E-mail address: sales@newtonson4th.com
 office@newtonson4th.com

web site: www.newtonson4th.com

At Newtonson4th Ltd. we have a policy of continuous product improvement and are always keen to hear comments, whether favourable or unfavourable, from users of our products.