

APPLICATION NOTE - 006

High voltage capacitance measurement with the PSM3750

Introduction

Some high voltage devices have different characteristics at the lower voltages usually used to measure capacitance. The LPA400 can be used with a PSM3750 to analyse devices at up to 800V pk-pk from dc to 100kHz and up to 80V pk-pk up to 1MHz. Measurements of capacitance, ac resistance, $\tan(\delta)$, and even power can be made under controlled conditions that are representative of the real operating conditions for the device.

Making the measurements

WARNING: the LPA400 can generate lethal voltages. Ensure that it is switched off when making the connections. Only use approved safety test leads and accessories.

In order to measure capacitance or power an external shunt is required. As the LPA400 is limited to around 50mA rms output into a reactive load, a non-inductive resistance of 10Ω is suitable (burden voltage of less than 1V). Connect up as shown below:

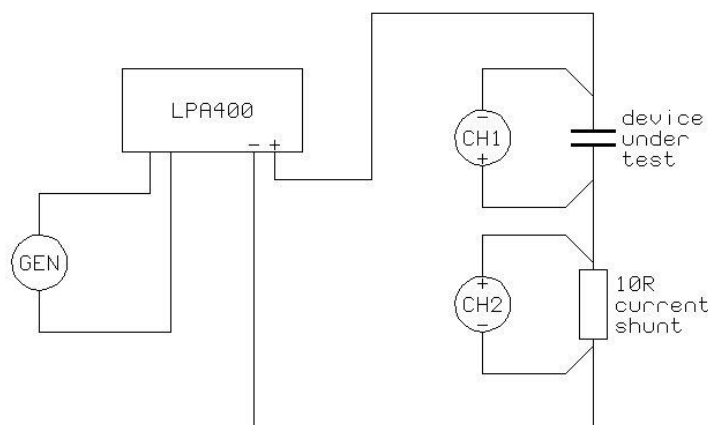

Note the polarity of the connections: the signal inputs for both channels are connected to the junction of the device and the shunt in order to minimise the loading effects of common mode capacitance to ground. Also, although the PSM3750 has excellent common mode rejection ratio (CMRR), it is wise to connect the shunt in the 0V path to minimise the common mode signal.

Set the LPA400 switches to AC+DC coupling, LOW bandwidth (unless operating above 80kHz), and gain x50. On the PSM3750, enter the shunt value for CH2 and measurements may now be made in the normal way using LCR mode, or power meter mode. When using LCR mode select passive head in the SETUP menu. The easiest way to set the test voltage level is to press OUT then NEXT and enable ac trim on ch1 with the desired rms level in the ac trim value.